

**HIGGINS
65" COPPER DOUBLE
SLIPPER TUB**

Cat. No.
COTHXN65-AC-AC



L: 64 1/2"
W: 33 1/2"
H: 27 3/4"

Water depth: 15 1/4" to overflow

Features:

- ▶ Constructed of 16 gauge copper
(Copper is a living finish and will patina over time)
- ▶ Hammered antique copper inside and out
- ▶ Hand polished
- ▶ No faucet holes
- ▶ With overflow
- ▶ Solid copper feet are attached before shipping
- ▶ Drain is in the center of the tub
- ▶ Hand-crafted construction makes each tub unique

Tub Finishes:

AC Antique Copper

The following is recommended for COTHXN tubs without faucet holes:

- Faucet: **Part #4602, 7393 or 7410**
- Freestanding bath supplies: **Part# 4502**
- Leg tub drain: **Part# 5599**

Gallon Capacity:	64
Shipping Weight:	325 lbs.
Empty Weight:	100 lbs.
Filled Weight:	635 lbs.

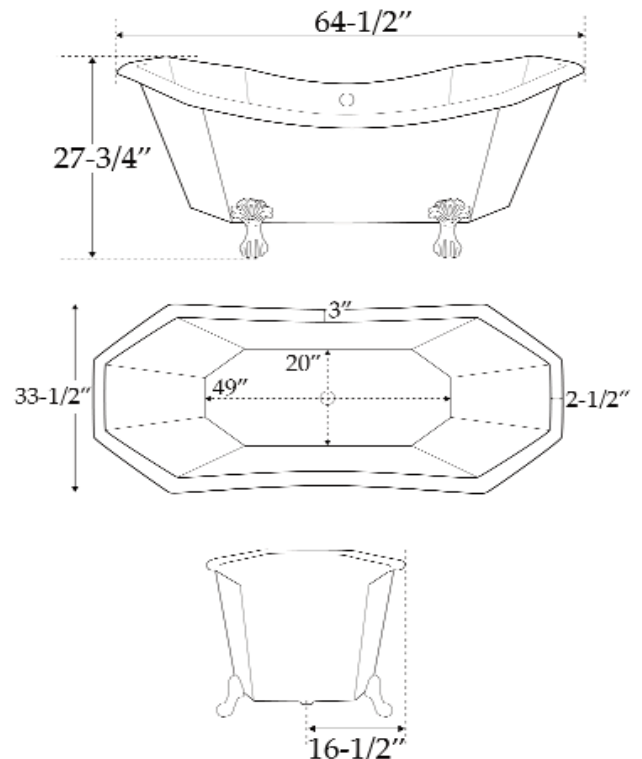

Dimensions and specifications subject to change without notice.